

# Solutions for Powertrain

TRANSLINE 2000  
Sample Applications

**SIEMENS**

# Overview of Solutions for Powertrain TRANSLINE 2000 Documentation

## General Documentation

### Solutions for Powertrain

TRANSLINE 2000  
Overview

### Solutions for Powertrain

TRANSLINE 2000  
Advertising  
Brochure

## Project Specific Documentation

### Solutions for Powertrain

TRANSLINE 2000  
Component List

## User Documentation

### Solutions for Powertrain

TRANSLINE 2000  
Sample  
Application

### Solutions for Powertrain

TRANSLINE 2000  
Visualization  
Operation  
Diagnostics

### Solutions for Powertrain

TRANSLINE 2000  
Data Backup

### Solutions for Powertrain

TRANSLINE 2000  
Safety Integrated

### Solutions for Powertrain

TRANSLINE 2000  
IT-Solutions

### Solutions for Powertrain

TRANSLINE 2000  
IT-Configuration

## Manufacturer Documentation

### Solutions for Powertrain

TRANSLINE 2000  
Software Guide

General  
S7-Graph  
S7-HiGraph

# SIEMENS

Solutions for Powertrain

TRANSLINE 2000 - Sample  
Applications

Manual

User Documentation

03.02 Edition

<b>General</b>	<b>1</b>
<b>Applications</b>	<b>2</b>
	<b>3</b>
	<b>4</b>
	<b>5</b>
	<b>6</b>
	<b>7</b>
	<b>8</b>
	<b>9</b>
	<b>10</b>
	<b>11</b>
	<b>12</b>
<b>Appendix</b>	<b>A</b>
<b>Index</b>	<b>I</b>

# SINUMERIK® Documentation

## Printing history

Brief details of this edition and previous editions are listed below.

The status of each edition is shown by the code in the „Remarks“ column.

*Status codes in the „Remarks“ column:*

- A ....** New documentation.
- B ....** Unrevised reprint with new Order No.
- C ....** Revised edition with new status.

<b>Edition</b>	<b>Order No.</b>	<b>Remarks</b>
03.01	6FC5297-0AG01 - 0BP0	<b>A</b>
03.02	6FC5297-0AG01 - 0BP1	<b>C</b>

Further information is available on the Internet under:  
<http://www.ad.siemens.de/sinumerik>

This publication was produced with WinWord V 7.0 and Designer V 6.0 using the documentation tool AutWinDoc.

The reproduction, transmission or use of this document or its contents is not permitted without express written authority. Offenders will be liable for damages. All rights, including rights created by patent grant or registration of a utility model or design, are reserved.

© Siemens AG 1995- 2001. All Rights Reserved.

Other functions not described in this documentation might be executable in the control. This does not, however, represent an obligation to supply such functions with a new control or when servicing.

We have checked that the contents of this document correspond to the hardware and software described. Nonetheless, differences might exist. The information contained in this document is, however, reviewed regularly and any necessary changes will be included in the next edition. We welcome suggestions for improvement.

Subject to change without prior notice.

# Preface

## Information on the structure of this document

This documentation is organized in 3 parts:

- General documentation
- User documentation
- Manufacturer/Service Documentation

## Target group

This document is intended for the manufacturers of machines incorporating SINUMERIK 840D, SIMODRIVE 611D and SIMATIC S7.

## Purpose

The manual explains the putting into action of Solutions for Powertrain by sample applications.

## Search aids

To help the reader, this guide offers not only a list of contents, but also the following appendices:

1. Abbreviations
2. Index of changes
3. Key word index

## Notes

The following notes have a special significance and are used in the documentation:

---

### Note

This symbol appears in the documentation whenever background information is provided.

---



### Important

This symbol appears in the documentation whenever attention has to be paid to something of particular importance

---

## Warning notes

The following warning notes with different level of severity are used in this publication:



---

### Danger

This symbol appears whenever death, severe bodily injury or substantial material damage **will** occur if the appropriate precautions are not taken.

---



---

### Warning

This symbol appears whenever death, severe bodily injury or substantial material damage **can** occur if the appropriate precautions are not taken.

---



---

### Caution

This symbol appears whenever minor bodily injury or material damage **can** occur if the appropriate precautions are not taken.

---

---

### Caution

This warning (without warning triangle) appears whenever material damage **can** occur if the appropriate precautions are not taken.

---

### Notice

Notice indicates that an undesirable state or event **may** result if the appropriate advice is not followed.

---

## Technical Notes

### Trademarks

IBM<sup>®</sup> is registered trademark of International Business Corporation.  
MS-DOS<sup>®</sup> and WINDOWS<sup>™</sup> is a registered trademark of Microsoft Corporation.

Norton Ghost<sup>®</sup> is a registered trademark of SYMATEC.

SIMATIC<sup>®</sup>, SIMATIC HMI<sup>®</sup>, SIMATIC NET<sup>®</sup>, SIROTEC<sup>®</sup>, SINUMERIK<sup>®</sup>,  
SIMODRIVE<sup>®</sup>, A&D DataManagement<sup>™</sup> are trademarks of SIEMENS.

Other product names used in this documentation may be trademarks which, if used by third parties, could infringe the rights of their owners.

## Notes

# Contents

Preface .....	0-5
1 General.....	1-11
2 Applications .....	2-13
2.1 Transfer Line .....	2-13
2.1.1 Head Control (PLC).....	2-14
2.1.2 Head Control (NC) .....	2-15
2.1.3 PLC Unit.....	2-16
2.1.4 Positioning Unit .....	2-17
2.1.5 NC Unit .....	2-18
2.2 Flexible Line .....	2-19
2.2.1 Head Control - Loading Portal.....	2-20
2.2.2 NC Manufacturing Cell.....	2-21
2.3 Assembly Lines .....	2-22
2.3.1 Automatic Station on a PLC Basis .....	2-23
2.3.2 Automatic Station with Transportation and Manual Workplaces .....	2-24
2.4 Assembly Line - Soft PLC Concept .....	2-25
2.5 Special Machine .....	2-26
2.5.1 PLC-Based.....	2-26
2.5.2 NC-Based .....	2-27
2.5.3 NC-based M:N .....	2-28
2.6 Machining Centres, NC Series Machines, Grinding Machines .....	2-29
2.7 Standalone Loaders/Portals .....	2-30
2.8 Link/Transportation Section.....	2-31
2.9 Overview of Applications .....	2-32
A Appendix.....	A-33
A.1 Abbreviations .....	A-33
A.2 Index of changes.....	A-38
A.2.1 Changes from Version 2.3.1 to Version 03.01 .....	A-38
A.2.2 Changes from Version 03.01 to Version 03.02 .....	A-38
I Index.....	I-39
I.1 Key word index.....	I-39

# 0 Figures

Figure 2-1	Complete Overview of Transfer Line	13
Figure 2-2	Transfer Line – Head Control on a PLC Basis	14
Figure 2-3	Transfer Line – Head Control on a NC Basis	15
Figure 2-4	Transfer Line – PLC Unit	16
Figure 2-5	Transfer Line – Positioning Unit	17
Figure 2-6	Transfer Line – CNC Unit	18
Figure 2-7	Complete Overview of Flexible Line	19
Figure 2-8	Flexible Line – Head Control – Loading Portal	20
Figure 2-9	Flexible Line – NC Manufacturing Cell	21
Figure 2-10	Complete Overview of Assembly Line	22
Figure 2-11	Assembly Line – Automatic Station on a PLC Basis	23
Figure 2-12	Assembly Line – Transportation and Manual Workstation	24
Figure 2-13	Assembly Line – Soft PLC Concept	25
Figure 2-14	PLC-Based Special Machine	26
Figure 2-15	NC-Based Special Machine	27
Figure 2-16	NC-Based Special Machine M:N	28
Figure 2-17	Machining Centres, NC Series Machines, Grinding Machines	29
Figure 2-18	Loaders/Portals	30
Figure 2-19	Link/Transportation Section	31

# 1 General

# 1

In this part of the Solutions for Powertrain TRANSLINE 2000 documentation package, we will show you sample applications for transfer lines, flexible lines, assembly lines special machines and other applications, as well as listing sample configurations in table form.

You can tailor the components in the examples to the technical requirements or applications in the individual projects.

For this, you can choose from the entire range of Solutions for Powertrain TRANSLINE 2000 standard components.



## Notes

## 2 Applications

# 2

The different applications are described in the points below

### 2.1 Transfer Line

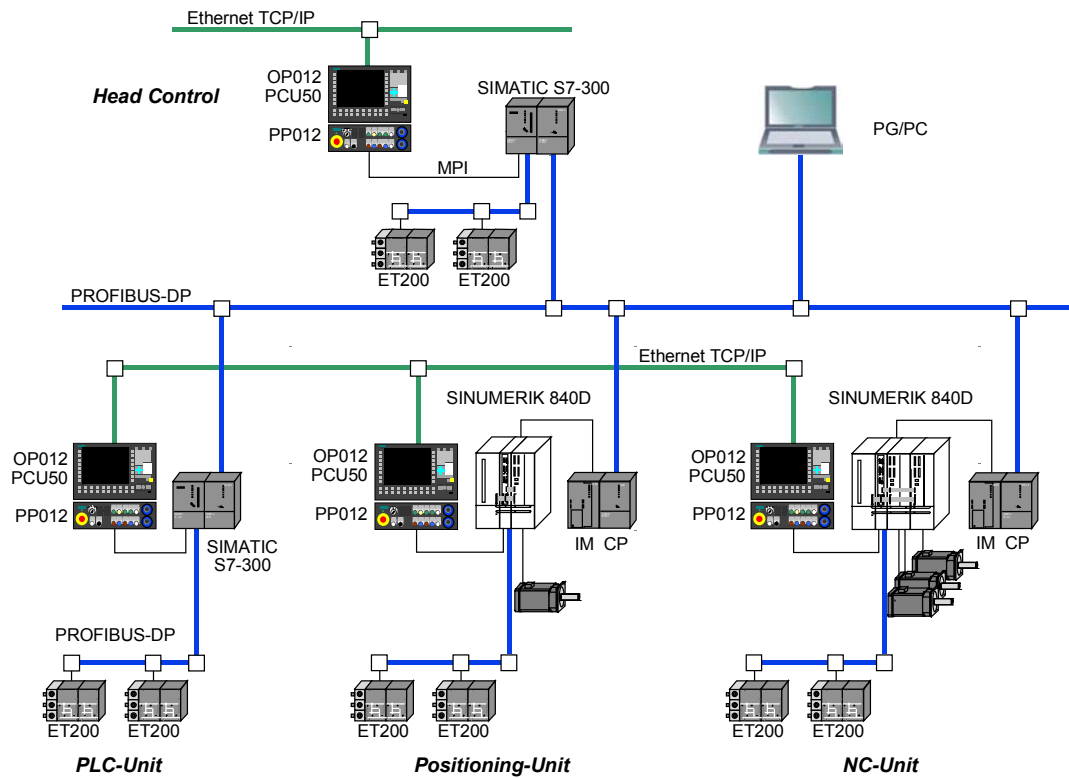

Figure 2-1 Complete Overview of Transfer Line

### 2.1.1 Head Control (PLC)

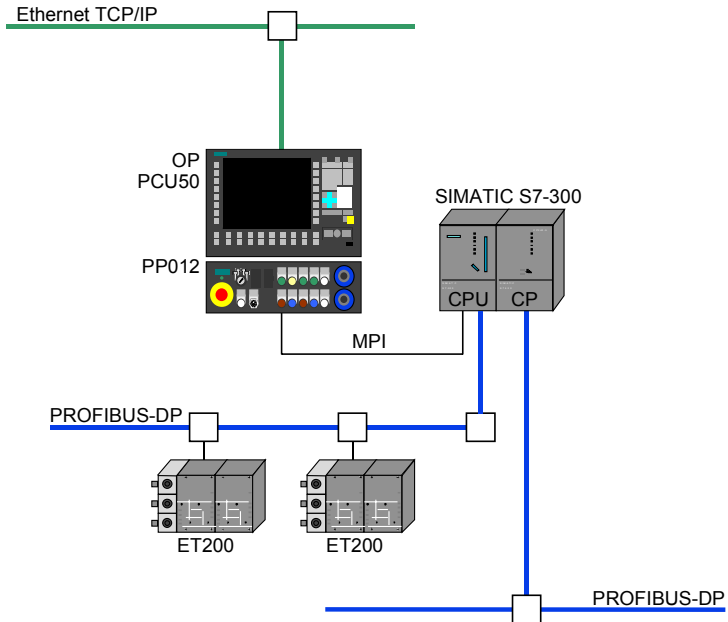

Figure 2-2 Transfer Line – Head Control on a PLC Basis

Operating & Monitoring Software	OP012/OP015A/PCU50 and PP012 TRANSLINE 2000 HMI PRO
Positioning	-
PLC	CPU 318-2DP
PROFIBUS-DP to peripherals to the units	Integrated DP-SS of CPU 318-2DP CP 342-5
Ethernet TCP/IP	Integrated PCU50 bus adapter
Distributed peripherals	ET200X, ET200S, ET200L
Drive	-
Motors	-

## 2.1.2 Head Control (NC)

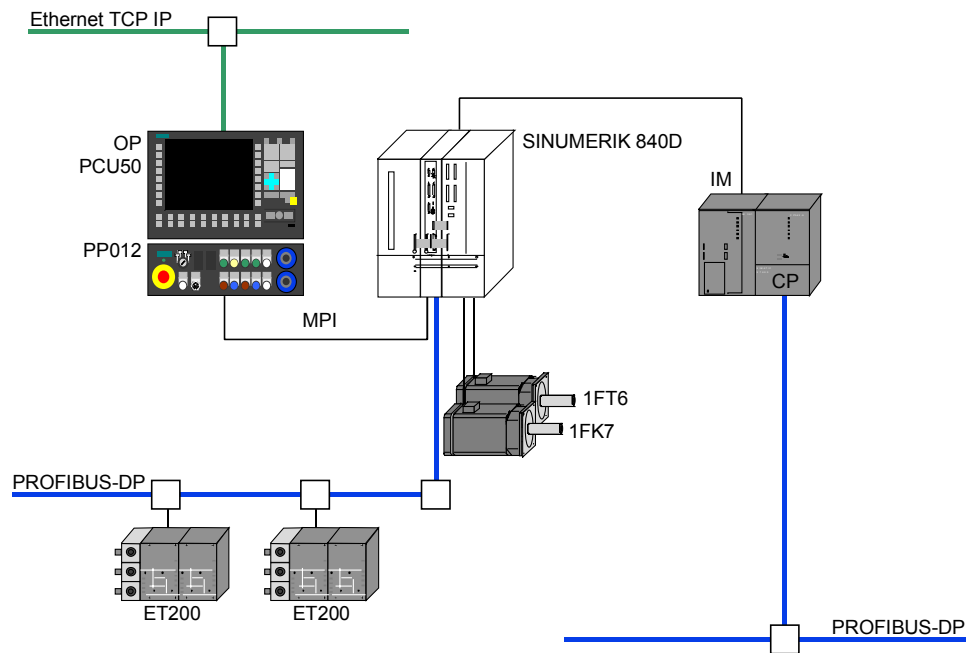

Figure 2-3 Transfer Line – Head Control on a NC Basis

Operating & Monitoring Software	OP012/OP015A/PCU50 and PP012 TRANSLINE 2000 HMI PRO
CNC	SINUMERIK NCU
PLC	Integrated CPU of SINUMERIK 840D
PROFIBUS-DP to peripherals to the units	Integrated DP-SS of the SINUMERIK 840D CP 342-5
Ethernet TCP/IP	Integrated PCU50 bus adapter
Distributed peripherals	ET200X, ET200S, ET200L
Drive	SIMODRIVE 611 digital
Motors	SIMODRIVE 1FT6 / 1FK7

### 2.1.3 PLC Unit

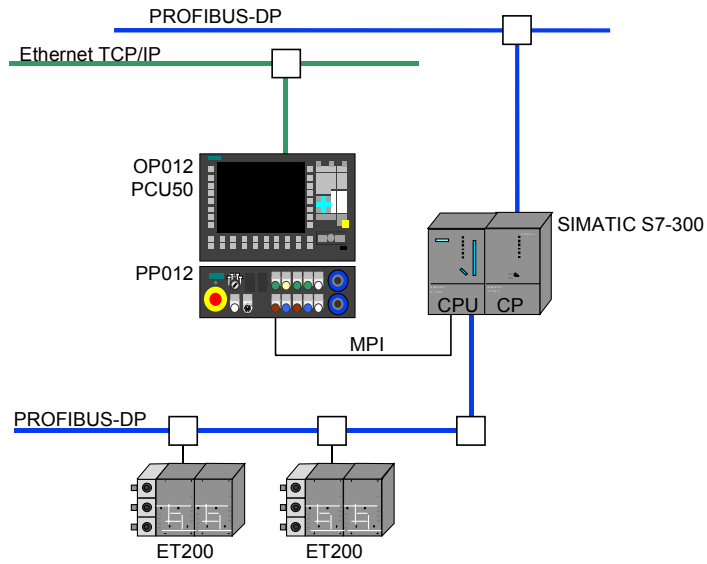

Figure 2-4 Transfer Line – PLC Unit

Operating & Monitoring Software	OP012/PCU50 and PP012 TRANSLINE 2000 HMI PRO
Positioning	-
PLC	CPU 315-2DP
PROFIBUS-DP to peripherals to head control	Integrated DP-SS of CPU CP 342-5
Ethernet TCP/IP	Integrated PCU50 bus adapter
Distributed peripherals	ET200X, ET200S, ET200L
Drive	-
Motors	-

### 2.1.4 Positioning Unit

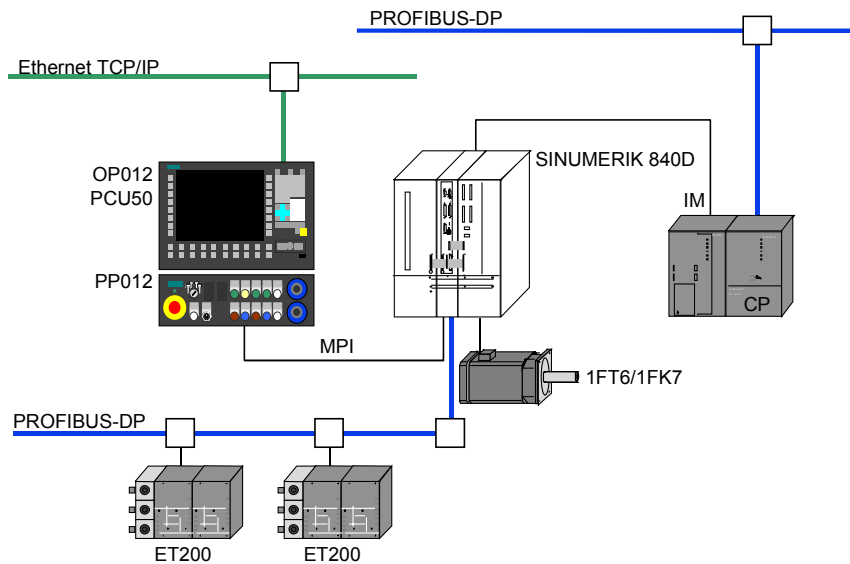

Figure 2-5 Transfer Line – Positioning Unit

Operating & Monitoring Software	OP012/PCU50 and PP012 TRANSLINE 2000 HMI PRO
CNC	SINUMERIK NCU 561.x
PLC	Integrated CPU of SINUMERIK 840D
PROFIBUS-DP to peripherals to head control	Integrated DP-SS of SINUMERIK 840D CP 342-5
Ethernet TCP/IP	Integrated PCU50 bus adapter
Distributed peripherals	ET200X, ET200S, ET200L
Drive	SIMODRIVE 611 digital
Motors	SIMODRIVE 1FT6 / 1FK7

### 2.1.5 NC Unit

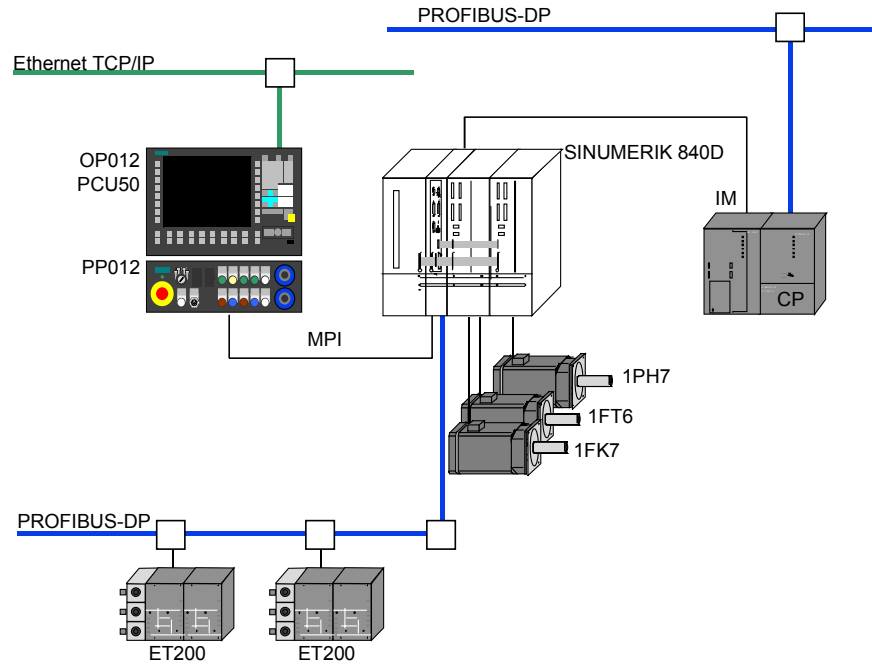

Figure 2-6 Transfer Line – CNC Unit

Operating & Monitoring Software	OP012/PCU50 and PP012 TRANSLINE 2000 HMI PRO
CNC	SINUMERIK NCU 571.x / 572.x / 573.x
PLC	Integrated CPU of SINUMERIK 840D
PROFIBUS-DP to peripherals to head control	Integrated DP-SS of the SINUMERIK 840D CP 342-5
Ethernet TCP/IP	Integrated PCU50 bus adapter
Distributed peripherals	ET200X, ET200S, ET200L
Drive	SIMODRIVE 611 digital
Motors	SIMODRIVE 1FT6 / 1PH7 / 1FK7

## 2.2 Flexible Line

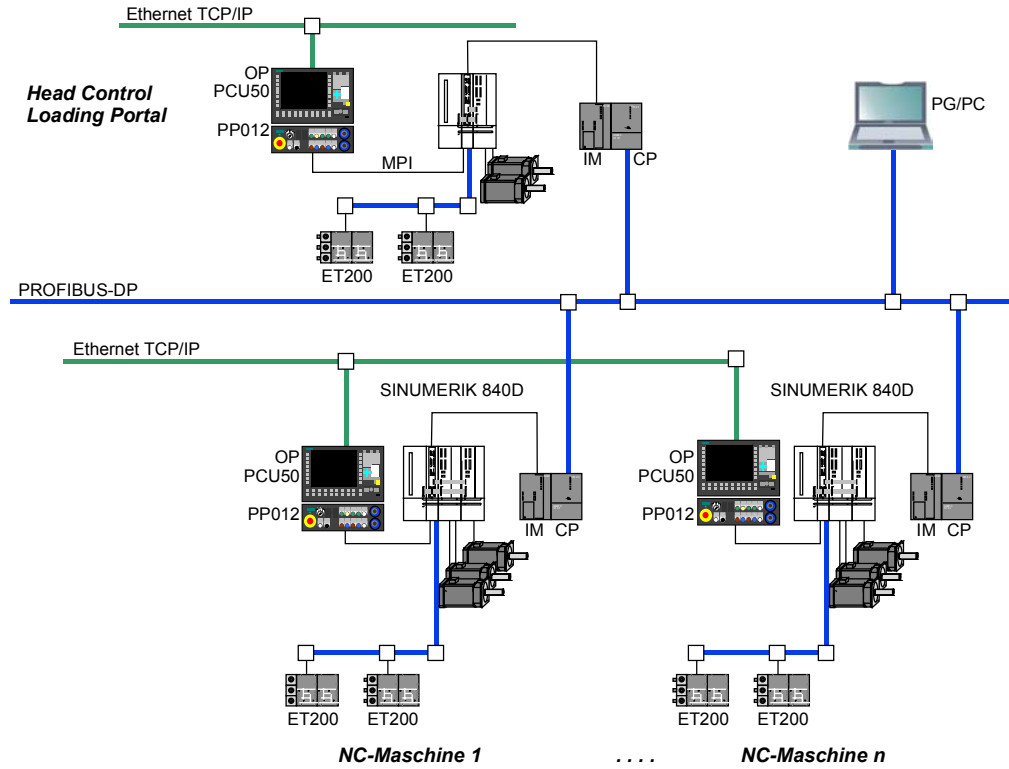

Figure 2-7 Complete Overview of Flexible Line

### 2.2.1 Head Control - Loading Portal

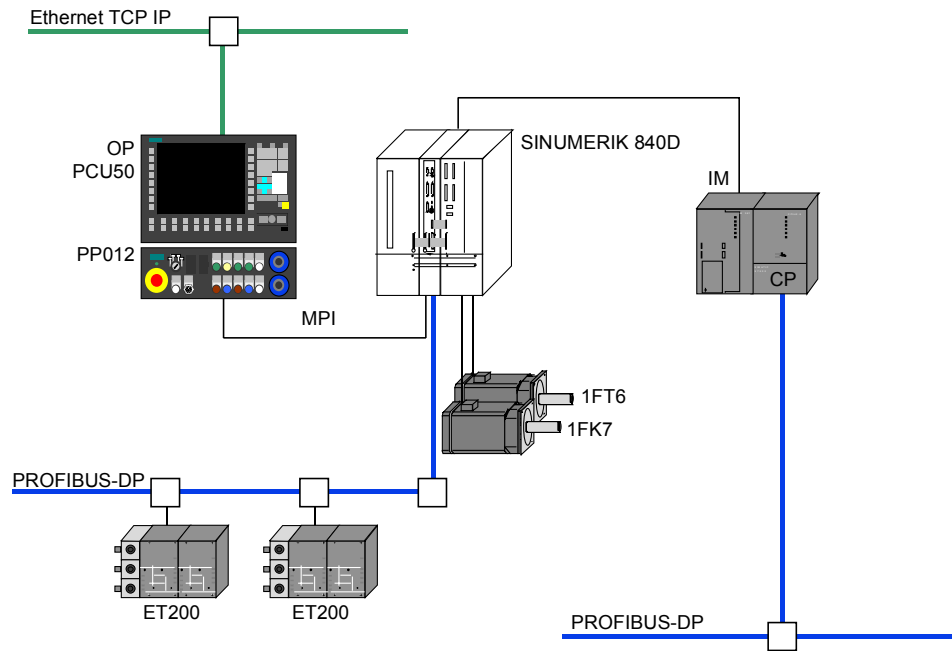

Figure 2-8 Flexible Line – Head Control – Loading Portal

Operating & Monitoring Software	OP012/OP015A/PCU50 and PP012 TRANSLINE 2000 HMI PRO
CNC	SINUMERIK NCU 561.x / 571.x
PLC	Integrated CPU of SINUMERIK 840D
PROFIBUS-DP to peripherals to the units	Integrated DP-SS of the SINUMERIK 840D CP 342-5
Ethernet TCP/IP	Integrated PCU50 bus adapter
Distributed peripherals	ET200X, ET200S, ET200L
Drive	SIMODRIVE 611 digital
Motors	SIMODRIVE 1FT6 / 1FK7

## 2.2.2 NC Manufacturing Cell

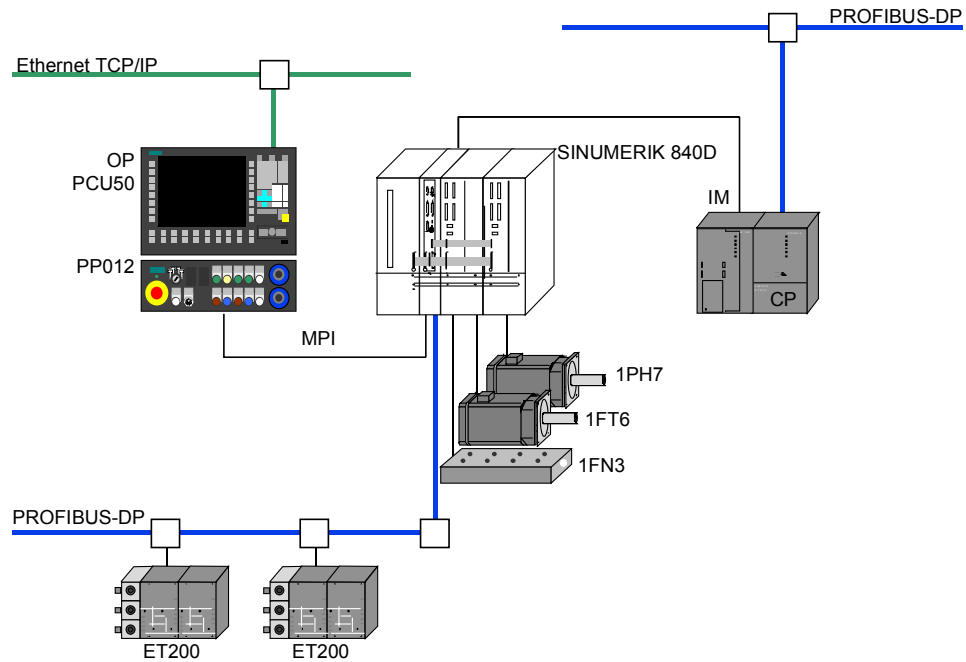

Figure 2-9 Flexible Line – NC Manufacturing Cell

Operating & Monitoring Software	OP012/OP015A/PCU50 and PP012 TRANSLINE 2000 HMI PRO
CNC	SINUMERIK NCU 571.x / 572.x / 573.x
PLC	Integrated CPU of SINUMERIK 840D
PROFIBUS-DP to peripherals to the units	Integrated DP-SS of the SINUMERIK 840D CP 342-5
Ethernet TCP/IP	Integrated PCU50 bus adapter
Distributed peripherals	ET200X, ET200S, ET200L
Drive	SIMODRIVE 611 digital
Motors	SIMODRIVE 1FT6 / 1PH7 / 1FN3

## 2.3 Assembly Lines

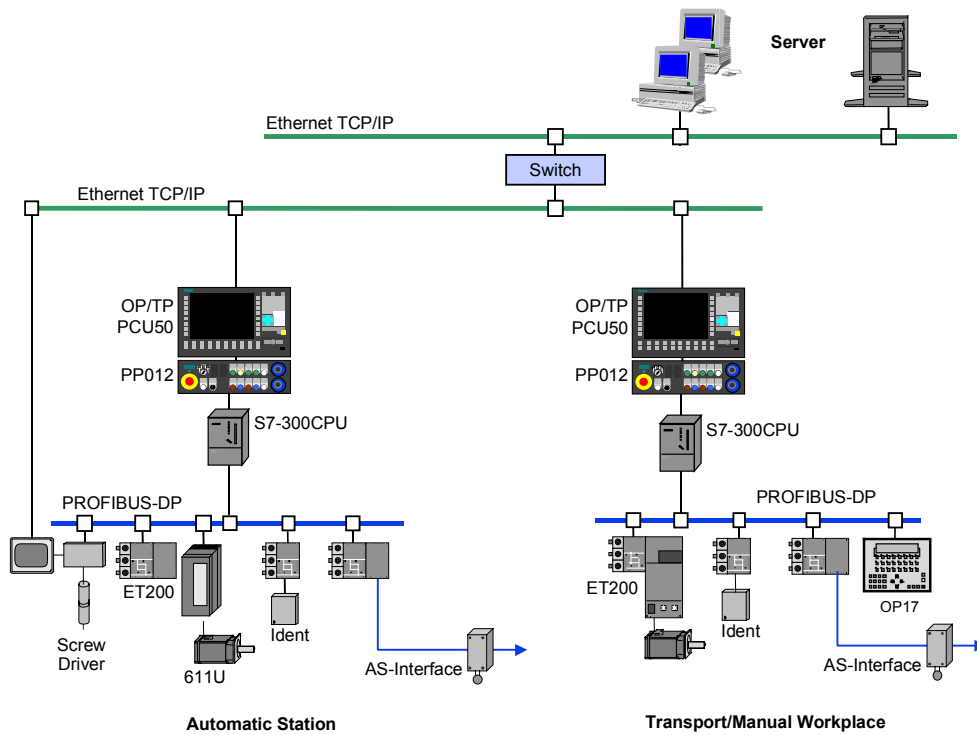

Figure 2-10 Complete Overview of Assembly Line

### 2.3.1 Automatic Station on a PLC Basis

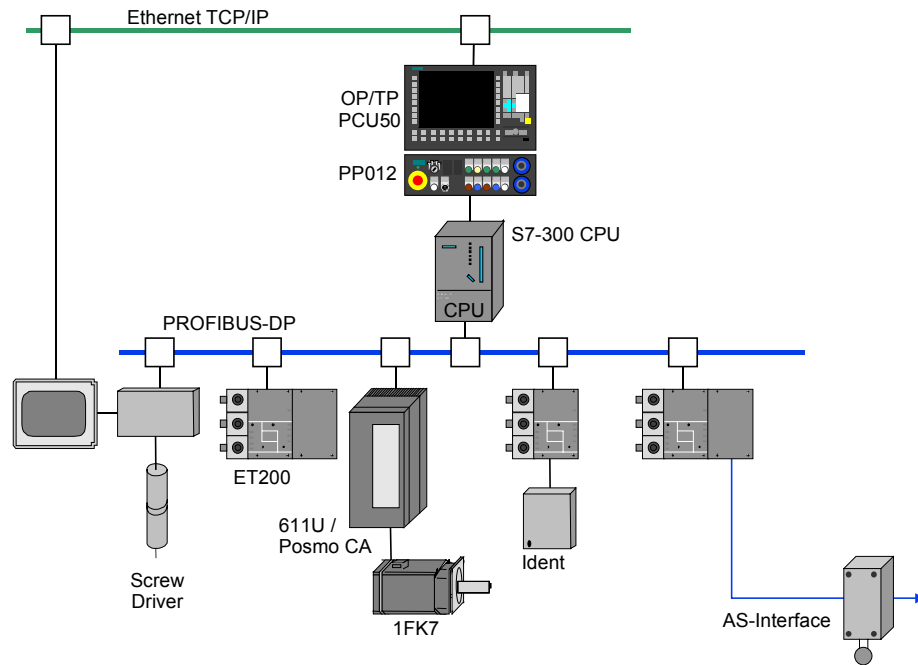

Figure 2-11 Assembly Line – Automatic Station on a PLC Basis

Operating & Monitoring Software	OP012/TP012S/PCU50 and PP012 TRANSLINE 2000 HMI PRO
PLC	CPU 315-2DP
PROFIBUS-DP to peripherals	Integrated DP-SS of CPU 315-2DP
Ethernet TCP/IP	Integrated PCU50 bus adapter
Distributed peripherals	ET200X, ET200S, ET200L, ASi
Identification system	MOBY ASM450 / ASM473
Drive	SIMODRIVE 611 universal / Posmo CA
Motors	SIMODRIVE 1FK7 / standard motor

### 2.3.2 Automatic Station with Transportation and Manual Workplaces

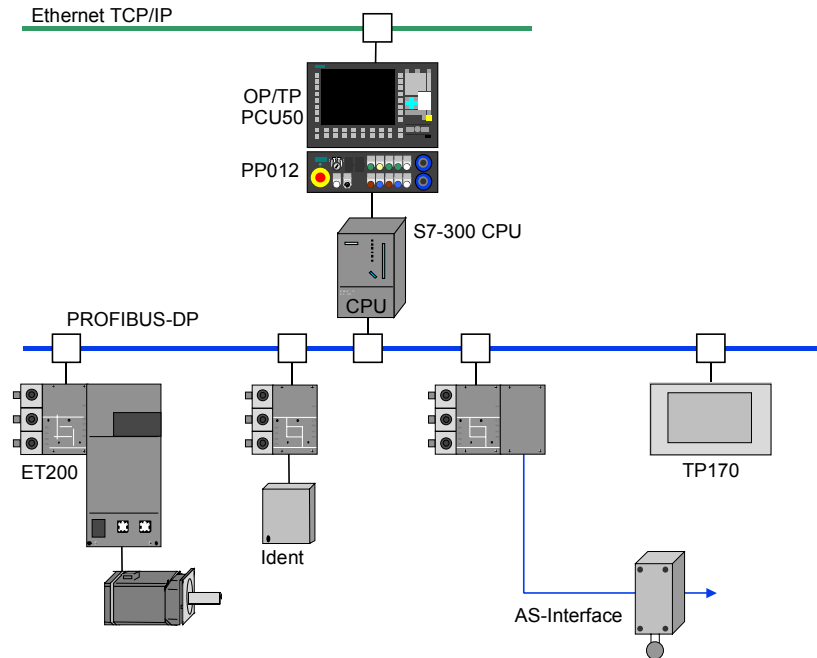

Figure 2-12 Assembly Line – Transportation and Manual Workstation

Operating & Monitoring Software	OP012/TP012S/PCU50 and PP012 TRANSLINE 2000 HMI PRO
Positioning/Frequency converter Transportation	ET200X Starter / reversing starter / frequency converter
Manual workstation	-
PLC	CPU 315-2DP
PROFIBUS-DP	Integrated DP-SS of CPU 315-2DP
Ethernet TCP/IP	Integrated PCU50 bus adapter
Distributed peripherals	ET200X, ET200S, ET200L, ASi
Identification system	MOBY ASM450 / ASM473
Drive	SIMODRIVE 611 universal / Posmo CA
Motors	SIMODRIVE 1FK7 / standard motor

## 2.4 Assembly Line - Soft PLC Concept

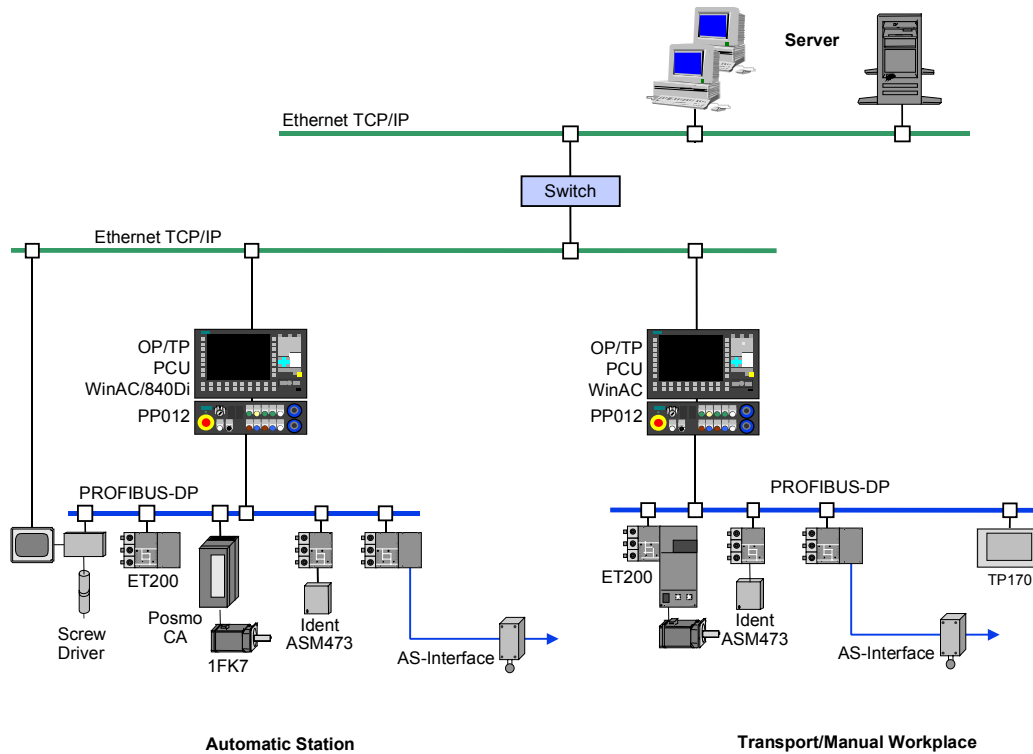

Figure 2-13 Assembly Line – Soft PLC Concept

Operating & Monitoring Software	OP012/TP012S/PCU50 and PP012/SIPC TRANSLINE 2000 HMI PRO
Positioning/Frequency converter Automatic Station Transportation	SIMODRIVE 611 universal ET200X Starter / reversing starter / frequency converter
CNC	SINUMERIK 840Di
PLC	WinAC Slot / RTX
PROFIBUS-DP	Integrated DP-SS of WinAC
Distributed peripherals	ET200X, ET200S, ET200L, ASi
Identification system	MOBY ASM450 / ASM473
Drive	SIMODRIVE 611 universal / Posmo CA
Motors	SIMODRIVE 1FK7

## 2.5 Special Machine

### 2.5.1 PLC-Based

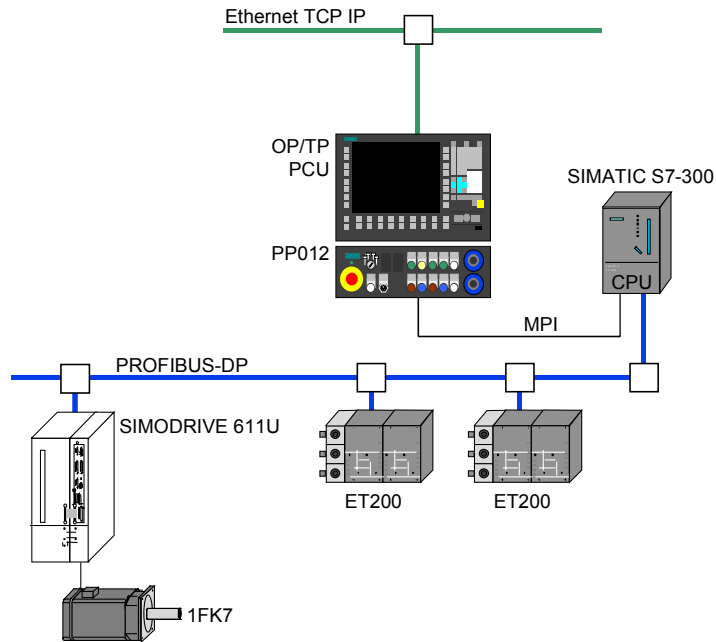

Figure 2-14 PLC-Based Special Machine

Operating & Monitoring Software	OP012/OP015A/TP012S/PCU50/PCU70 and PP012 TRANSLINE 2000 HMI PRO
Positioning	SIMODRIVE 611 universal
PLC	CPU 316-2DP / CPU 318-2DP
PROFIBUS-DP to peripherals	Integrated DP-SS of CPU
Ethernet TCP/IP	Integrated PCU50 bus adapter
Distributed peripherals	ET200X, ET200S, ET200L
Drive	SIMODRIVE 611 universal
Motors	SIMODRIVE 1FK7

## 2.5.2 NC-Based

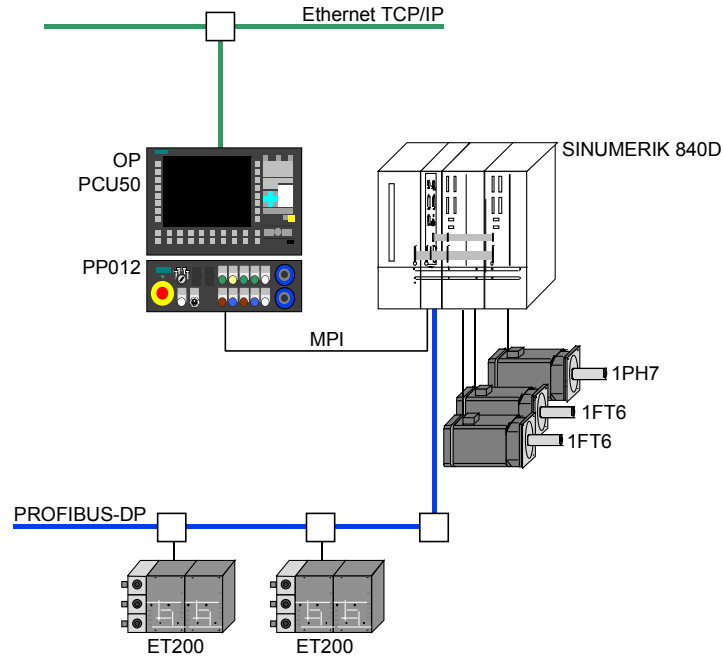

Figure 2-15 NC-Based Special Machine

Operating & Monitoring Software	OP012/OP015A/PCU50 and PP012 TRANSLINE 2000 HMI PRO
CNC	SINUMERIK NCU561.x / 571.x / 572.x / 573.x
PLC	Integrated CPU of SINUMERIK 840D
PROFIBUS-DP to peripherals	Integrated DP-SS of SINUMERIK 840D
Ethernet TCP/IP	Integrated PCU50 bus adapter
Distributed peripherals	ET200X, ET200S, ET200L
Drive	SIMODRIVE 611 digital
Motors	SIMODRIVE 1FT6 / 1PH7

### 2.5.3 NC-based M:N

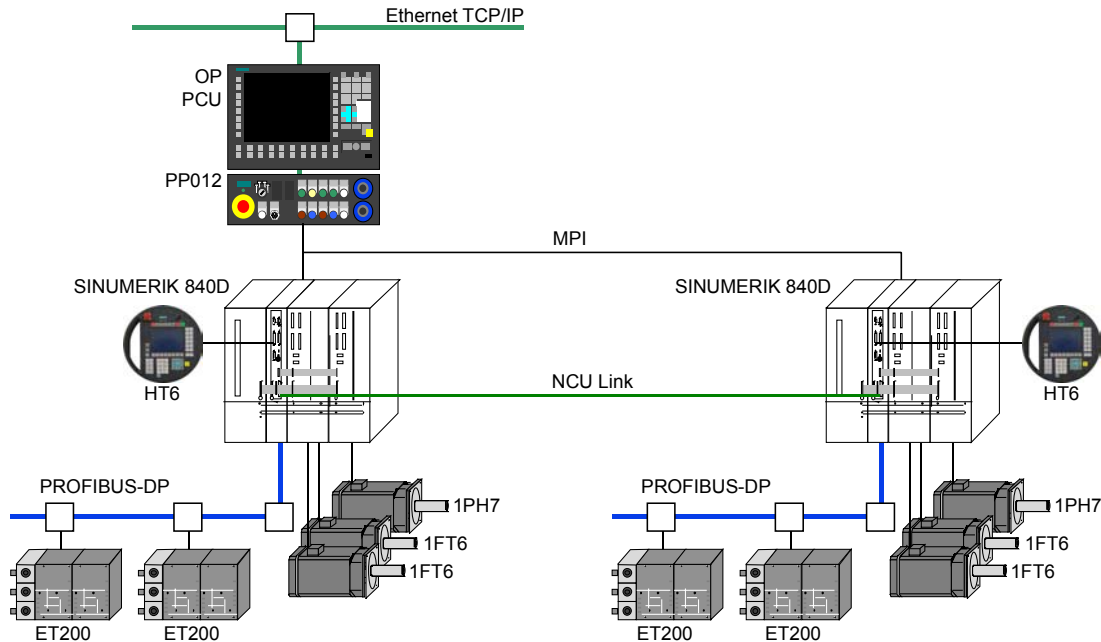

Figure 2-16 NC-Based Special Machine M:N

Operating & Monitoring Software	OP012/OP015A/PCU50 and PP012 TRANSLINE 2000 HMI PRO <sup>1</sup>
CNC	SINUMERIK NCU573.x
PLC	Integrated CPU of SINUMERIK 840D
PROFIBUS-DP to peripherals	Integrated DP-SS of SINUMERIK 840D
Ethernet TCP/IP	Integrated PCU50 bus adapter
Distributed peripherals	ET200X, ET200S, ET200L
Drive	SIMODRIVE 611 digital
Motors	SIMODRIVE 1FT6 / 1PH7

<sup>1</sup> The HMI PRO is permanently switched to an NCU

## 2.6 Machining Centres, NC Series Machines, Grinding Machines

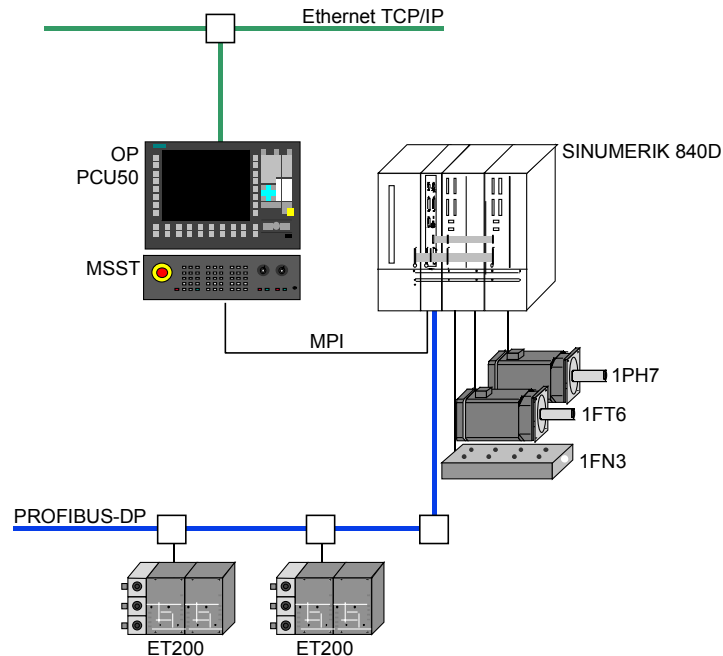

Figure 2-17 Machining Centres, NC Series Machines, Grinding Machines

Operating & Monitoring Software	OP012/OP015A/PCU50 and MSST Standard user interface of SINUMERIK 840D and TRANSLINE 2000 HMI PRO
CNC	SINUMERIK NCU 572.x / 573.x
PLC	Integrated CPU of SINUMERIK 840D
PROFIBUS-DP to peripherals Ethernet TCP/IP	Integrated DP-SS of the SINUMERIK 840D Integrated PCU50 bus adapter
Distributed peripherals	ET200X, ET200S, ET200L
Drive	SIMODRIVE 611 digital
Motors	SIMODRIVE 1FT6 / 1PH7 / 1FN3

## 2.7 Standalone Loaders/Portals

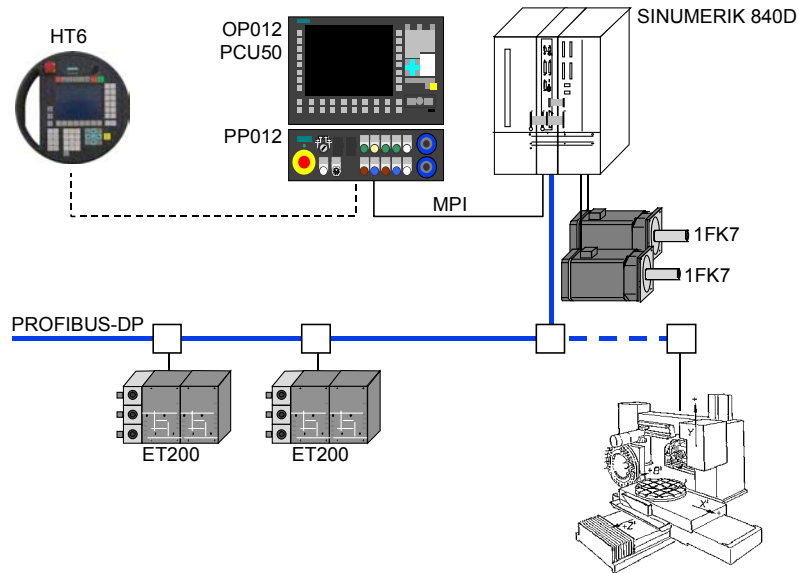

Figure 2-18 Loaders/Portals

Operating & Monitoring Software	OP012/PCU50 and PP012, option of HT6 Standard SINUMERIK 840D user interface
CNC	SINUMERIK NCU 561.x / 571.x / 572.x
PLC	Integrated CPU of SINUMERIK 840D
PROFIBUS-DP to peripherals	Integrated DP-SS of the SINUMERIK 840D
Distributed peripherals	ET200X, ET200S, ET200L
Drive	SIMODRIVE 611 digital
Motors	SIMODRIVE 1FK7

## 2.8 Link/Transportation Section

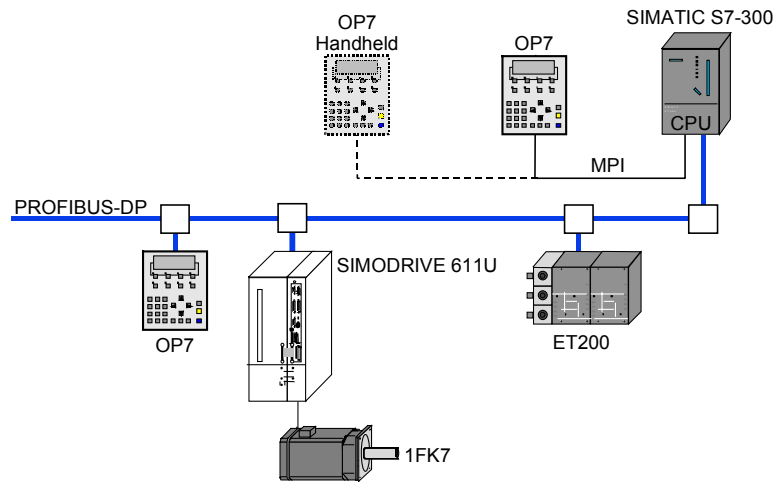

Figure 2-19 Link/Transportation Section

Operating & Monitoring	OP7 (permanently installed or hand-held)
CNCPositioning	SIMODRIVE 611 universal
PLC	CPU 315-2DP
PROFIBUS-DP to peripherals	Integrated DP-SS of CPU 315-2DP
Distributed peripherals	ET200X, ET200S, ET200L
Drive	SIMODRIVE 611 universal
Motors	SIMODRIVE 1FK7

## 2.9 Overview of Applications

Components	O&M	Controller	Drive	Motor
<b>Transfer line</b>				
Head control (PLC)	OP012/ OP015A/ PCU50	CPU 318-2DP		
Head control (NC)	OP012/ OP015A/ PCU50	NCU	SIMODRIVE 611 digital	1FT6 / 1FK7
PLC unit	OP012/PCU50	CPU 315-2DP		
Positioning unit	OP012/PCU50	NCU 561.x	SIMODRIVE 611 digital	1FT6 / 1FK7
NC unit	OP012/PCU50	NCU 571.x NCU 572.x NCU 573.x	SIMODRIVE 611 digital	1FT6 / 1FK7 / 1PH7
<b>Flexible Line</b>				
Head control loading portal	OP012/ OP015A/ PCU50	NCU 561.x NCU 571.x	SIMODRIVE 611 digital	1FT6 / 1FK7
NC manufacturing cell	OP012/ OP015A/ PCU50	NCU 571.x NCU 572.x NCU 573.x	SIMODRIVE 611 digital	1FT6 / 1PH7 / 1FN3
<b>Assembly Line</b>				
Automatic station (PLC)	OP012/ TP012S/ PCU50	CPU 315-2DP	SIMODRIVE 611 universal / Posmo CA	1FK7 / standard motor
Transportation and manual workplace	OP012/ TP012S/ PCU50/ TP170	CPU 315-2DP	SIMODRIVE 611 universal / Posmo CA	1FK7 / standard motor
<b>Assembly Line Soft-PLC Concept</b>				
Soft PLC Concept	OP012/ TP012S/ PCU50/ TP170	WinAC Slot / RTX	SIMODRIVE 611 universal / Posmo CA	1FK7
<b>Special Machine</b>				
PLC-based	OP012/ OP015A/ TP012S/ PCU50/70	CPU 316-2DP CPU 318-2DP	SIMODRIVE 611 universal	1FK7
NC-based	OP012/ OP015A/ PCU50	NCU 561.x NCU 571.x NCU 572.x NCU 573.x	SIMODRIVE 611 digital	1FT6 / 1PH7
NC-based M:N	OP012/ OP015A/ PCU50	NCU 573.x	SIMODRIVE 611 digital	1FT6 / 1PH7
Machining centres, CNC series machines, grinding machines	OP012/ OP015A/ PCU50	NCU 572.x NCU 573.x	SIMODRIVE 611 digital	1FT6 / 1PH7 / 1FN3
Loaders/portals	OP012/PCU50 opt. HT6	NCU 561.x NCU 571.x NCU 572.x	SIMODRIVE 611 digital	1FK7
Link transportation section	OP7	CPU 315-2DP	SIMODRIVE 611 universal	1FK7



# A Appendix

# A

## A.1 Abbreviations

1FT, 1FK 1PH	Designation for feed motors (1FT, 1FK) and main spindle motors (1PH).
A&D	Automation & Drives – SIEMENS Automation & Drives Group
ADDM	A&D DataManagement
ASCII	American Standard Code for Information and Interchange
AS-i	Actuator-Sensor Interface – bus system which allows control devices and actuators to be simply connected.
BCD	Binary coded digit
BDE	Operating data acquisition via networks
BTSS	Operator panel interface to couple operator panels for SINUMERIK 840D
CAM	Computer Aided Manufacturing
CD	Compact Disc
CE	Communauté Européenne –symbol for the EMC compatibility for electrical equipment
CNC	Computerized Numerical Control – for example SINUMERIK 840D
COM1/2	Communications interface for serial PC communications
CP	Communications Processor
CPU	Central Processing Unit
CRC	Cyclic Redundancy Check – cyclic block check for data transfer protocols
CS	Configuration System
CSF	Control System Flowchart to program PLC control systems
DB	Database
DIN	Deutsche Industrie Norm
DNC	Direct Numerical Control – i.e. NC programs are controlled and executed from the host computer
DOS	Disc operating system

DV	Data Processing
ECC	Error Correction Code
EDP	Electronic Data Processing
EDV	Electronic Data Processing
EMC	Electromagnetic compatibility of electrical components with each other
EN	European Standard
ESM	Electrical Switch Module
ET200X, ET200S, ET200L	Distributed I/O modules which can be connected to PROFIBUS
FB	Function Block
FC	Function Call
FOC	Fiber Optic Cable
GPS	Global Positioning System
H	Designates the version of the PP012 with the capability of connecting external operator control devices
HHU	Hand Held Unit
HLA	Hydraulic Linear Drives –SINUMERIK 840D module to couple hydraulic axes.
HMI	Human Machine Interface – standard operator interface for NC and machine control
HOME	Home-Position
HP	Hewlett Packart
HPU	Handheld control terminal – is used to locally control SINUMERIK controls
HR	Variant of PP031 with connector for external handheld units
I&S	Siemens Group, Industrial Services
IBM	International Business Machines
IBN	Start-up-Tool 611D to commission (start-up) digital drive systems
IEC 1131-3	International standard to program programmable logic controllers.
IO	Interlinked Operation
IP	Standardization for shock protection and protection against the ingress of water for electrical equipment and devices.
ISA	Industrial Standard Architecture – interface definition for PC expansion cards
ISDN	Integrated Services Digital Network

IT	Information Technology
IT DL	Information Technology, Services for Industrial Systems
ITP	IT Solutions for Powertrain
kbyte	Kilobyte – designates the memory size. 1kbyte is 1024 x 8 bits
L operation	Operator panel with keys on one side of the screen (right or left) and on the bottom side of the screen
LAN	Local Area Network – to network computer systems, generally via TCP/IP
LAP	Ladder diagram to program PLC control systems
LPT1	Line Printer – interface port to connect a printer
MCP	Machine control panel – standard operator panel for operating SINUMERIK NCs
MCU	Motion Control Unit – module in a 611 D drive with an NC axis and integrated PLC
MDA	Machine Data Acquisition
MDE	Machine Data Acquisition – production data acquisition from machines
MMC	Man Machine Communications – PC-based operator panel unit
MOD	Magnetic Optical Disk
MOP	Main Operator Panel
MP	Multi-Functional Platforms
MPI	Multi Point Interface – multi-point capable interface, coupling S7-PLC to programming devices or operator panels
MSST	Machine Control Panel – standard operator panel to control SINUMERIK NCs
MTBF	Meantime between failures
NC	Numerical Control – also refer to CNC
NCK	NC Kernel – central software section of a SINUMERIK control system
NCM	Network and Communications Manager – software to configure a network
NCU	Numerical Control Unit – module associated with a numerical control which is available with different levels of performance.
OA	Open architecture
OB	Organization Block
OEM	Original Equipment Manufacturer

OP	Operator Panel – operator panel to visualize and handle control systems. The number after the name specifies the operator panel type.
OP7-HH	OP7 handheld – portable OP7 with additional enable key
OP-A	Operator Panel for Assembly
OPM	Operating Mode
OPMG	Operating Mode Group
OSM	Optical Switch Module
OSM NM	Optical Switch Module Network Management
PC	Personal Computer
PCI	Peripheral Component Interconnect – bus definition for PC expansion cards
PCU	PC-Unit – PC-based operator control system based on a standard PC
PCU	PC Unit – PC-based operator control system based on a standard PC
PDA	Production Data Acquisition
PG	Programming Device – device based on a standard PC to program control systems
PLC	Programmable Logic Control – programmable logic controller, for example, an S7-300
PO	Production Order
PP012	Push Button Panel – operator panel for machine control with keys and override
PP012	Push Button Panel
PPS	Production Planning System
ProDiag	Process Diagnostic Software
PROFIBUS	Process Field Bus – the standards for devices connected to the bus are defined by the PNO – PROFIBUS User Organization
PROFIBUS DP	PROFIBUS protocol for communications with a distributed peripheral system, for example ET200X
RAID	Redundant Array of Independent Disks - hard disk system which tolerates hard disk failure.
RAM	Random Access Memory – read-write memory to save data
RAS	Remote Access Server
ROM	Read Only Memory
Router	Connecting element between two network segments, normally represented as PC with special software

RT	Run Time
SAP	Production planning system from SAP
SFC	System Function Call
SI	Immediate Stop
SL	Statement list to program PLC controls
SM	Single Mode
SPC	End of cycle
SS	Single Step Mode
SU	Setup Mode
SW	Software
SX	Processor name from Intel to designate a 16-bit data bus.
TCP/IP	Transmission Control Protocol / Internet Protocol – data transmission protocol for networked PCs
TD	Text display to display text, processes cannot be controlled
TFT	Thin film transistor
TO	Tool
TP	Touch Panel – Operator panel for the display and operation of controls with touch functions. The designation number indicates the type of control panel.
U operation	Operator panel with keys on the left, right bottom side of the screen
UDT	User Defined Data
UOP	Unit Operator Panel
UPS	Uninterruptable Power Supply
USB	Universal Serial Bus
V-24	Need a definition of V-24
VGA	Video Graphics Array
WAN	Wide Area Network
WIN AC	Windows Automation Center
WinTPM	Product designation of the software module for preventive maintenance (TPM - totally productive maintenance)
ZIP	ZIP drive from the IOMEGA company where data can be saved in a zipped (compressed) form

## **A.2 Index of changes**

### **A.2.1 Changes from Version 2.3.1 to Version 03.01**

No changes in the contents were made.

### **A.2.2 Changes from Version 03.01 to Version 03.02**

#### **Section 2.3 Assembly Lines**

Inclusion of the assembly line without master control

#### **Section 2.4 Assembly Lines - Soft PLC Concept**

Inclusion of the assembly line Soft-PLC concept

#### **Subsection 2.5.3 Special machine NC-based M/N**

Inclusion of the special machine on the NC basis M:N

#### **Section 2.6 Machining Centers, NC Series Machines, Grinding Machines**

Limitation to a concept without PP012

■

# I Index

## I.1 Key word index

### A

Assembly Line .....	2-22
Automatic Station on a PLC Basis.....	2-23
Automatic Station with Manual Workplaces2-	24
Automatic Station with Transportation.....	2-24
Soft PLC Concept.....	2-25

### F

Flexible Line.....	2-19
Head Control - Loading Portal.....	2-20
NC Manufacturing Cell .....	2-21

### L

Link/Transportation Section .....	2-31
-----------------------------------	------

### O

Overview of Applications .....	2-32
--------------------------------	------

### S

Special Machine .....	2-26
NC-Based .....	2-27
NC-Based M/N.....	2-28
PLC-Based .....	2-26
Standalone Loaders/Portals .....	2-30

### T

Transfer Line .....	2-13
Head Control (NC) .....	2-15
Head Control (PLC) .....	2-14
NC Unit .....	2-18
PLC Unit .....	2-16
Positioning Unit.....	2-17

## Notes

An  
Siemens AG

TRANSLINE Support  
P. O. Box 106026

D-70049 Stuttgart

(Tel. +49 (0) 711 / 137 - 3964

Fax +49 (0) 711 / 137 - 2838

email: TL2000.support@stg.siemens.de)

**Suggestions**

**Corrections**

For Publication/Manual:

Solutions for Powertrain

TRANSLINE 2000 - Sample Applications

User Documentation

**From**

Name

Company/Dept.

Address: \_\_\_\_\_  
\_\_\_\_\_

Telephone: \_\_\_\_\_ / \_\_\_\_\_

Telefax: \_\_\_\_\_ / \_\_\_\_\_

Manual

Order No.: 6FC5297-0AG01-0BP1  
03.02 Edition

Should you come across any printing errors when reading this publication, please notify us on this sheet. Suggestions for improvements are also welcome.

**Suggestions and/or corrections**



**Siemens AG**

Automation and Drives

Motion Control Systems

P.O. Box 3180, D – 91050 Erlangen

Federal Republic of Germany

[www.ad.siemens.de](http://www.ad.siemens.de)

© Siemens AG 2002

Reserved for changes

Order No.: 6FC5297-0AG01-0BP1

Printed in Federal Republic of Germany